



# INSTALLATION INSTRUCTIONS

Accessory

FRONT SIDE PIPE  
P/N 08P70-MKS-E00

Application

CRF1100A/D

Publication No.

MII

Issue Date

September 2019

**Honda Dealer: Please give a copy of these instructions to your customer.**

## PARTS LIST

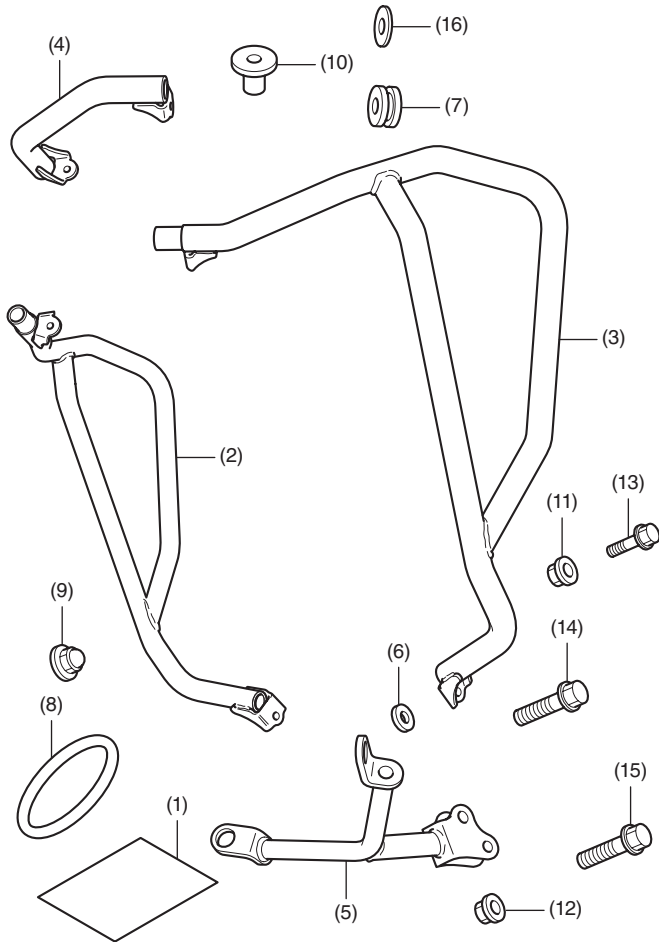

No.	Description	Qty
(1)	URL paper	1
(2)	Right front side pipe	1
(3)	Left front side pipe	1
(4)	Front side center pipe	1
(5)	Front side pipe center stay	1
(6)	Spacer (large)	2
(7)	Grommet	2
(8)	Gasket	2
(9)	8 mm flange cap nut	2
(10)	Collar	2
(11)	6 mm flange nut	2
(12)	8 mm flange nut	1
(13)	6 mm SH flange bolt	2
(14)	8 mm SH flange bolt	2
(15)	8 mm flange bolt (short)	2
(16)	Washer	2

## GUARD ATTACHMENT

Sold separately

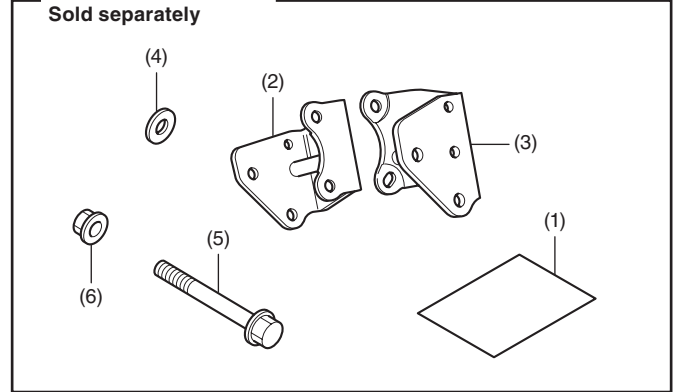

No.	Description	Qty
(1)	URL paper	1
(2)	Right guard bracket	1
(3)	Left guard bracket	1
(4)	Spacer (small)	2
(5)	8 mm flange bolt (long)	2
(6)	8 mm flange nut	2

## TOOLS AND SUPPLY REQUIRED

Socket (8, 10 and 12 mm)  
Ratchet  
Box-end wrench (10 and 12 mm)  
Shop towel  
Torque wrench

## TORQUE CHART

Tighten all screws, bolts, and nuts to their specified torque values. Refer to the Service Manual for the torque values of the removed parts.

Item	N-m	kgf-m	lbf-ft
6 mm flange nut	12	1.2	9
8 mm flange cap nut	27	2.8	20
8 mm flange nut	32	3.3	24

## INSTALLATION

### ⚠ CAUTION

- To prevent burns, allow the engine, exhaust system, radiator, etc., to cool before installing the accessory.

#### NOTE:

- Refer to this manual and the Engine guard Installation Instructions when the motorcycle is equipped with the Engine guard.
  - Disconnect the negative (-) cable from the battery before installing this accessory.
  - The memories of the clock will be erased when you disconnect the battery. Reset the memories after reconnecting the battery.
  - Reinstall the removed parts on the motorcycle and make sure that the wires and harnesses are not pinched.
  - Although the illustration is of CRF1100D, use the same procedures for other models.
1. Remove the tool box and disconnect the negative (-) cable of the battery.

<Left side>

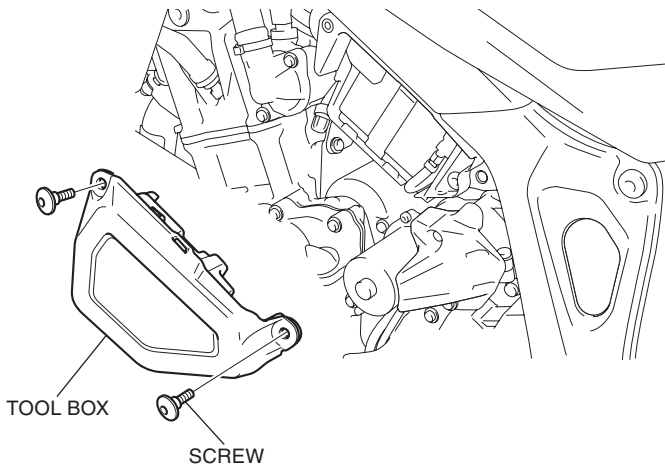

2. Remove the screw as shown.

- Repeat on the right side.

<Left side>

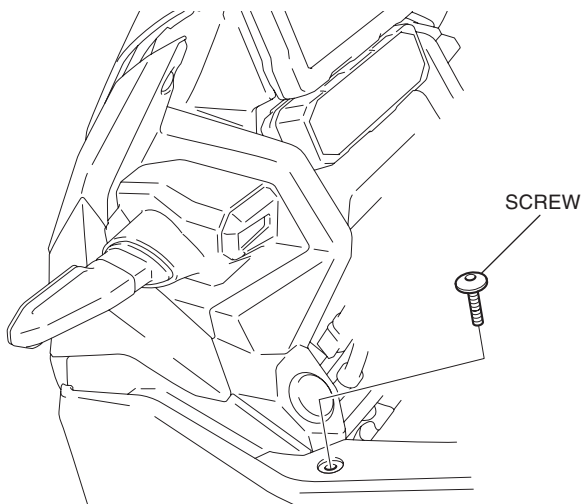

3. Remove the clips as shown.

- Repeat on the right side.

<Left side>

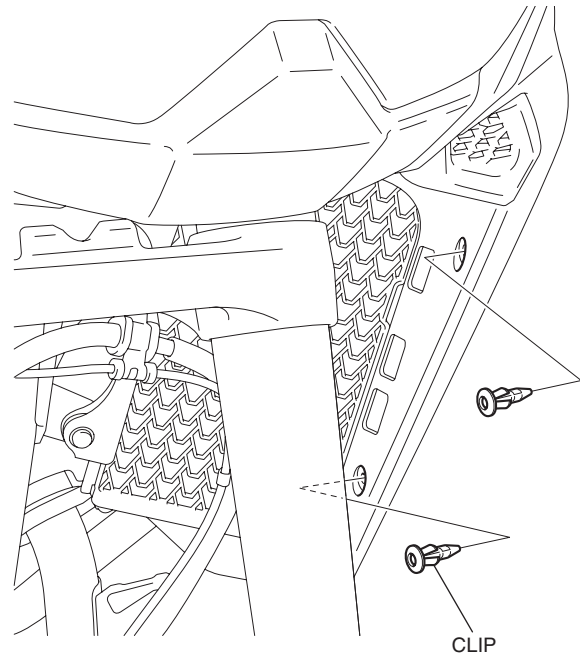

4. Remove the boss of the left middle cowl as shown.  
<Left side>

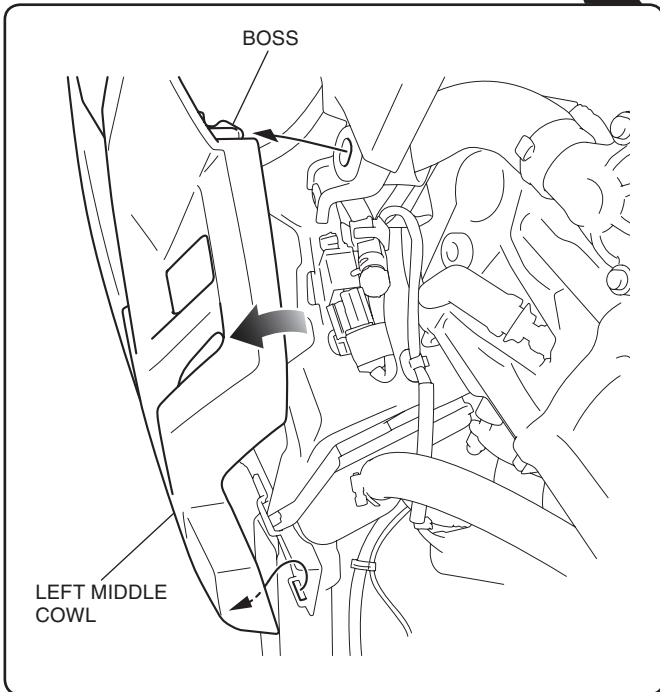
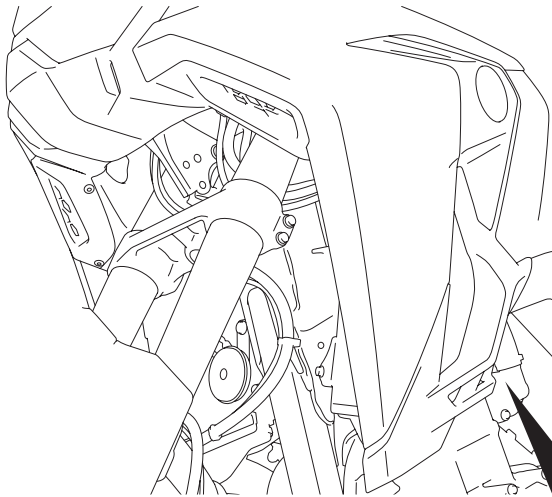

5. Remove the drain tube as shown.

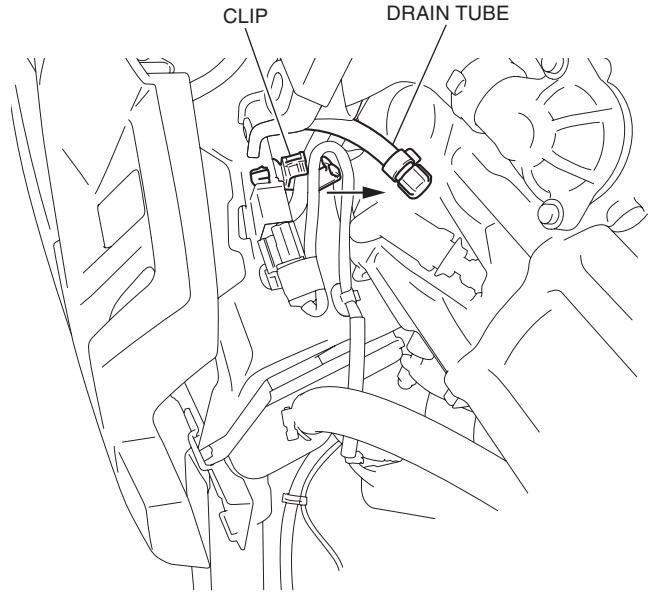

6. Remove the harness as shown.

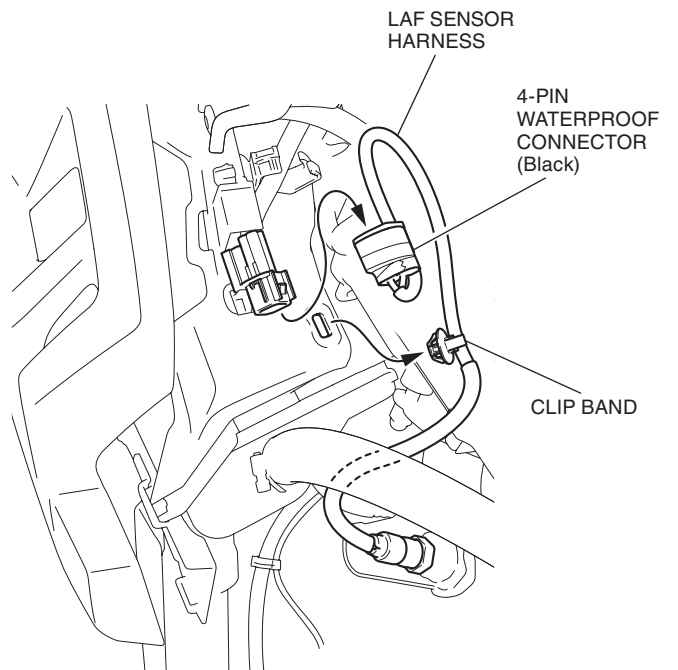

7. Remove the boss of the right middle cowl, and remove the screw as shown.

<Right side>

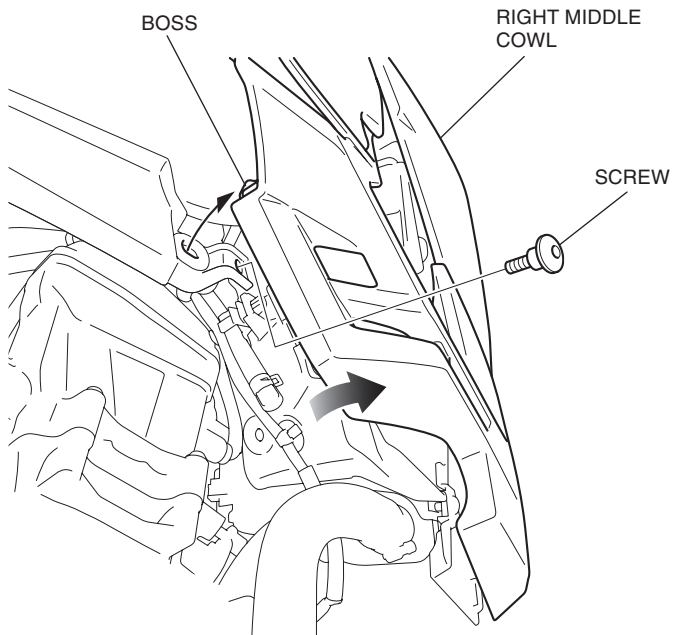

8. Remove the drain tube and LAF sensor harness in the same manner as the left side.

9. Remove the nuts as shown.

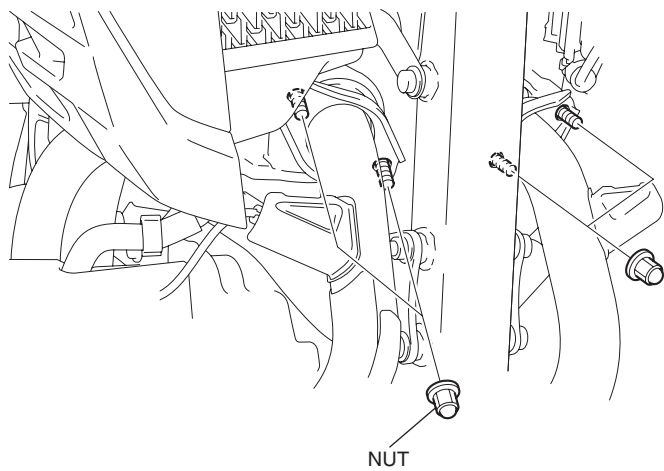

10. Remove the parts as shown.

<Right side>

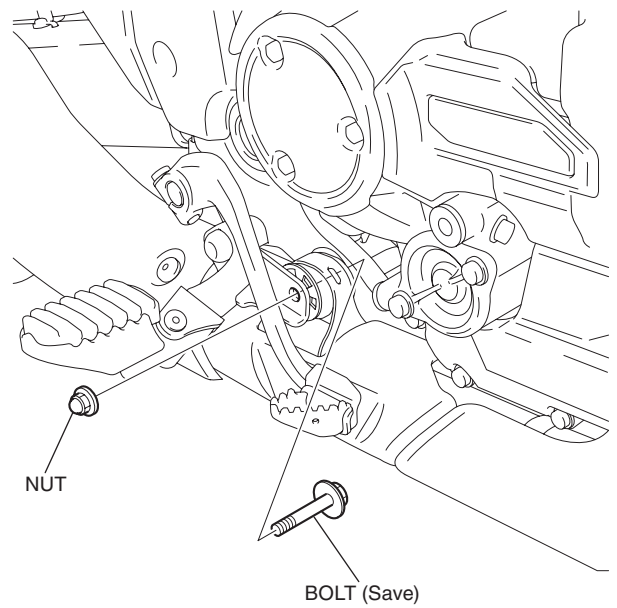

11. Protect the swing arm with a shop towel or similar.

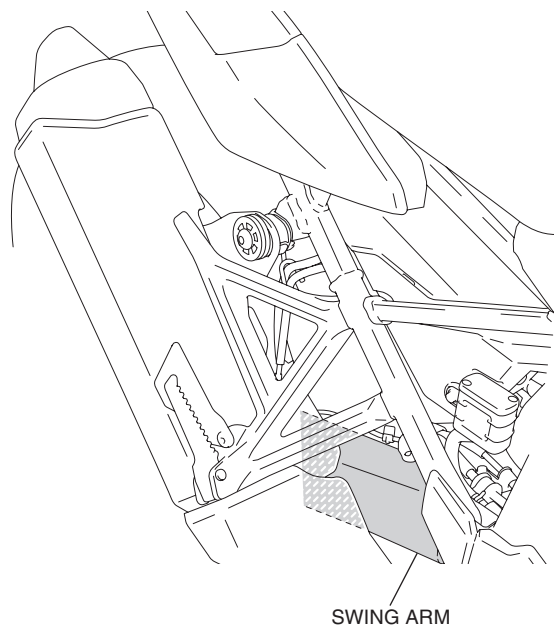

12. Remove the bolt, and then lower the muffler as shown.

- **Make sure that the one person keeps the lowered muffler, and the other installs the engine guard.**

Make sure that the cables is not burdened when the muffler is lowered.

CABLE

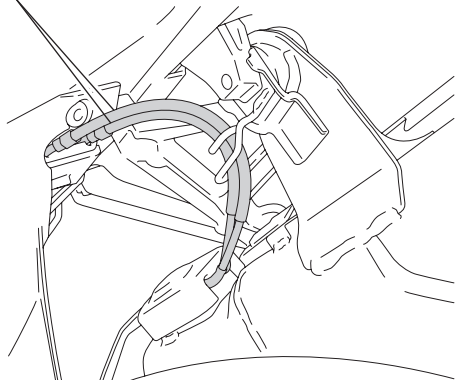

MUFFLER

WASHER

BOLT

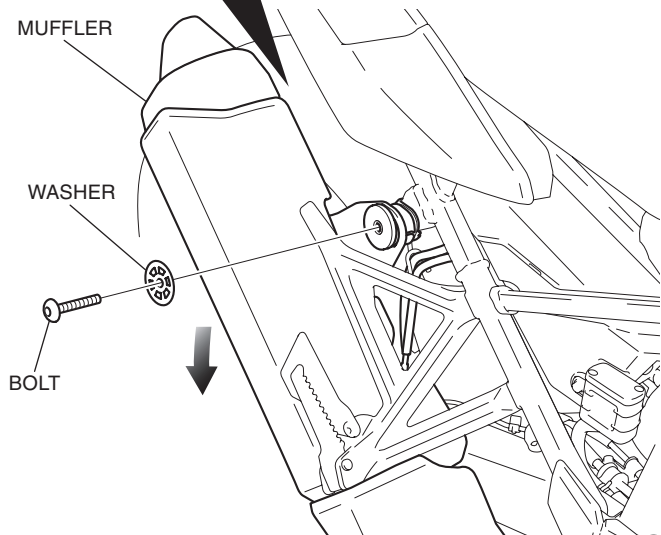

13. Remove the parts as shown.

<Left side>

BOLT (Save)

NUT (Save)

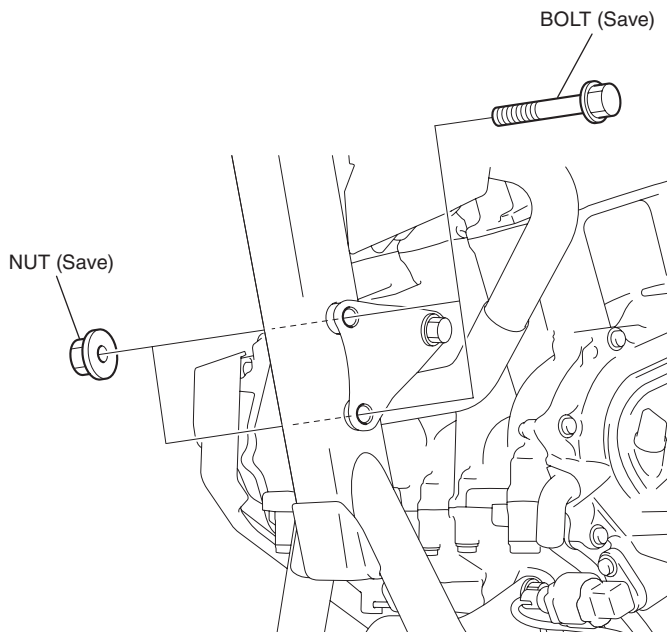

14. Insert the bolts as shown.

8 mm FLANGE BOLT (long)

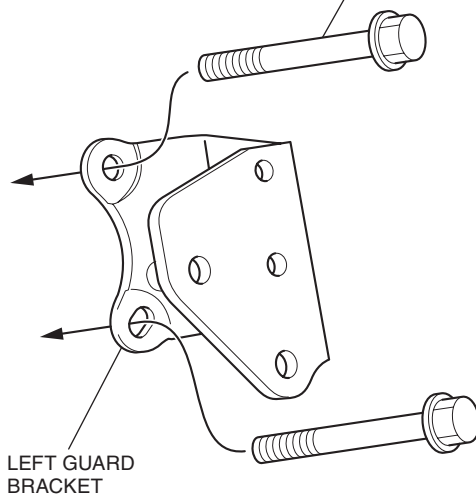

15. Install the left guard bracket as shown.

<Left side>

SPACER (small)

LEFT GUARD BRACKET

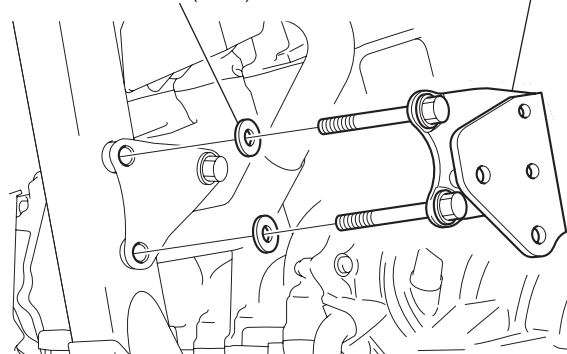

16. Install the right guard bracket as shown.

<Right side>

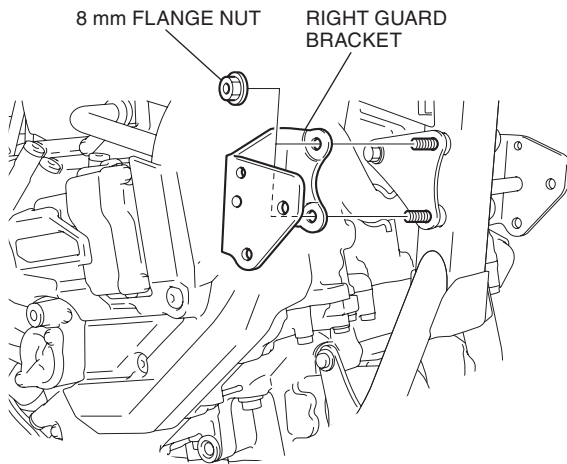

17. Install the muffler in the reverse order of removal.

- **Always replace by a new gasket.**

18. Install the right and left middle cowl, drain tube and LAF sensor harness in the reverse order of removal.

19. Remove the parts as shown.

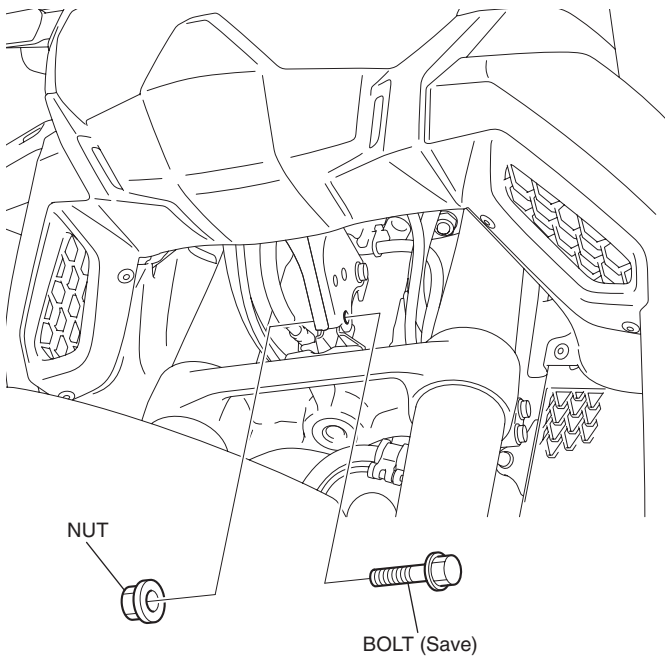

20. Install the grommets as shown.

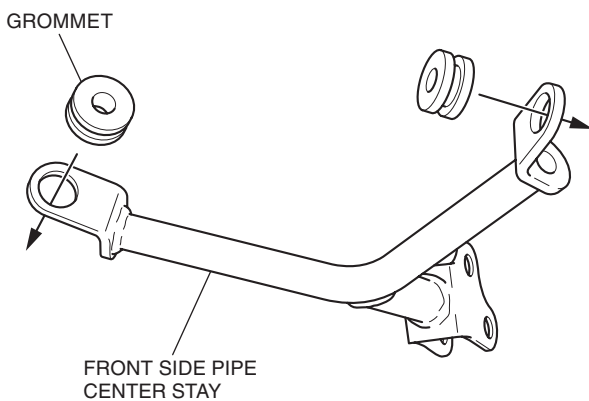

21. Install the collars to the front side pipe center stay as shown.

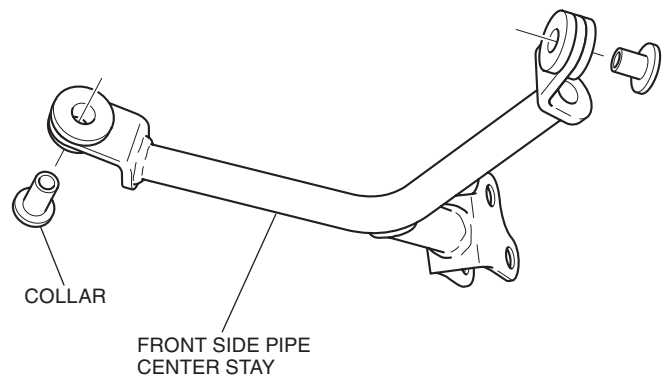

22. Install the front side center pipe as shown.

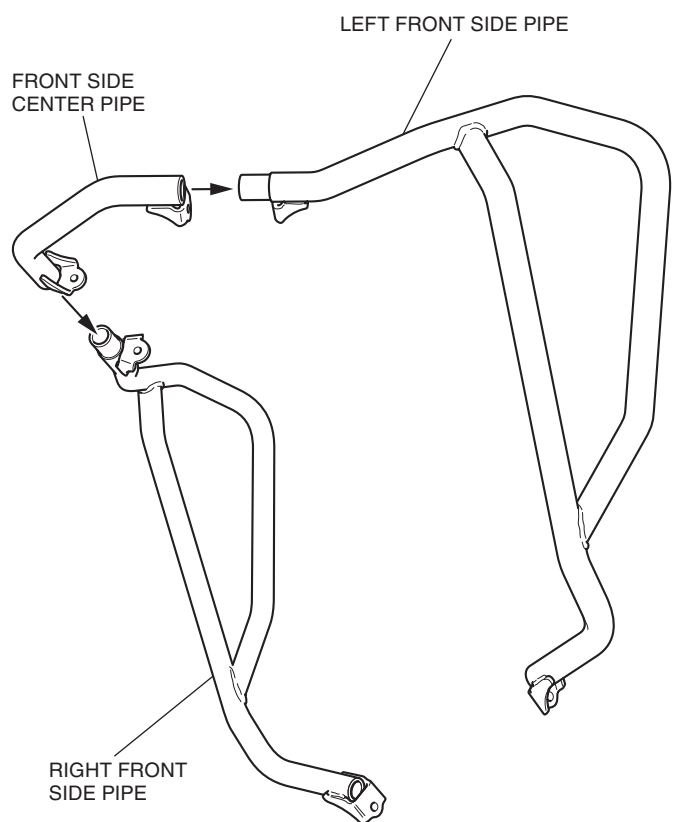

23. Loosely install the front side pipe center stay as shown.

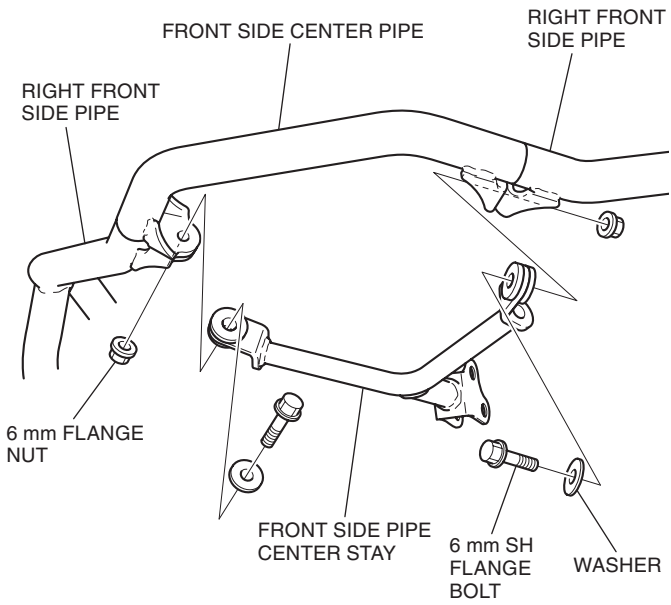

24. Remove the parts as shown.

- Perform this step for the motorcycle equipped with the engine guard.
- Repeat on the right side.

<Left side>

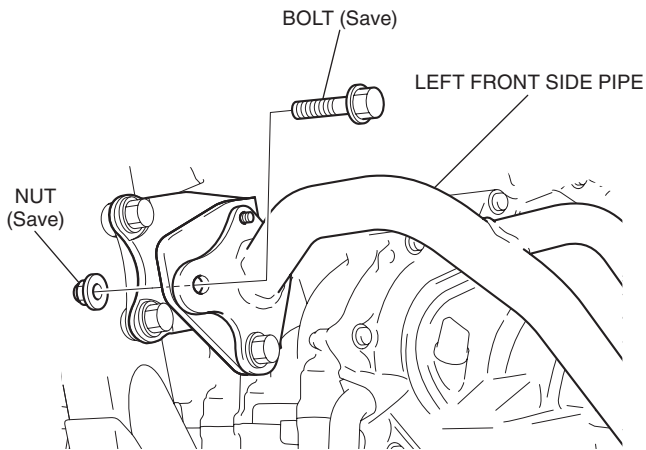

25. Loosely install the assembled front side pipe as shown.

- Repeat on the right side.

<Left side>

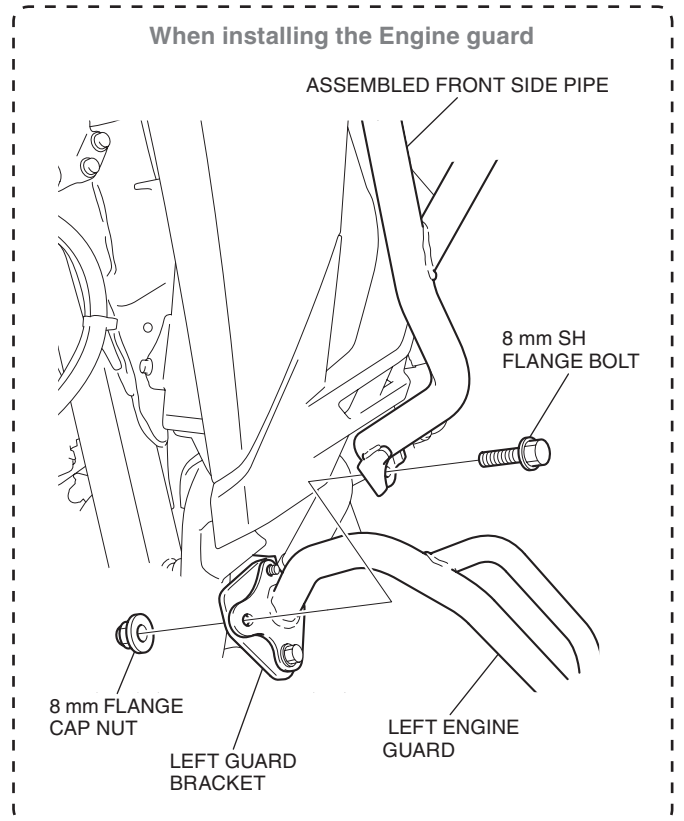
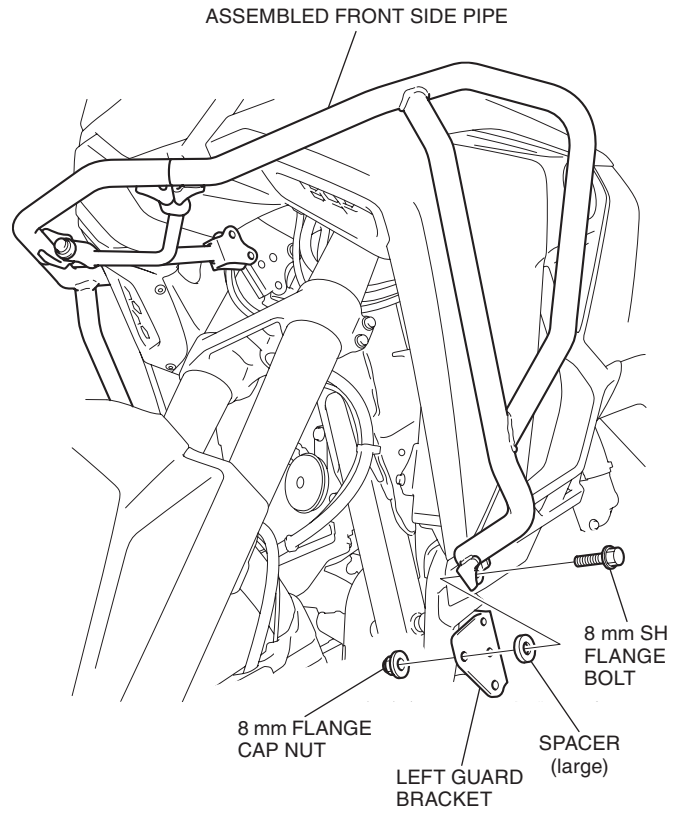

26. Raise and install the assembled front side pipe center stay as shown.

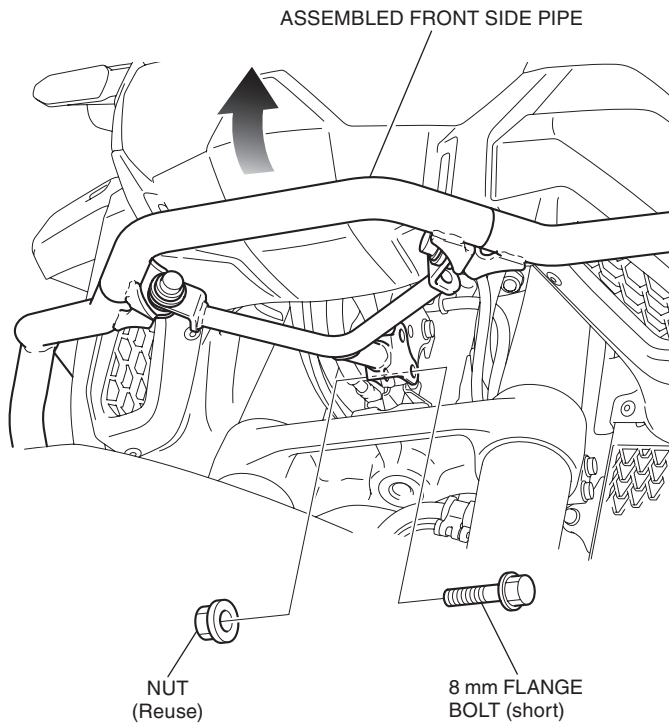

27. Install the parts as shown.

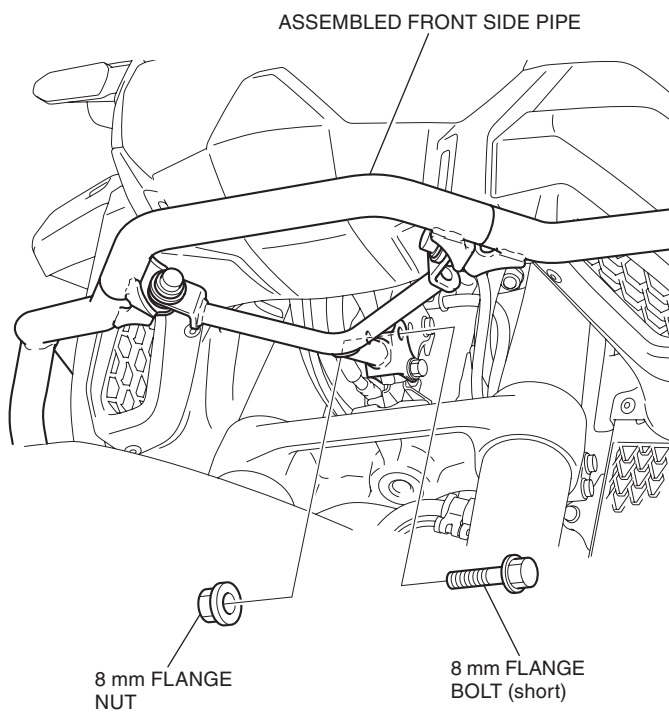

28. Tighten all loosely installed parts securely.
29. Install the motorcycle's parts in the reverse order of removal.
- **Confirm that any wire harness is not caught or too tight.**