

Honda Dealer: Please give a copy of these instructions to your customer.

PARTS LIST

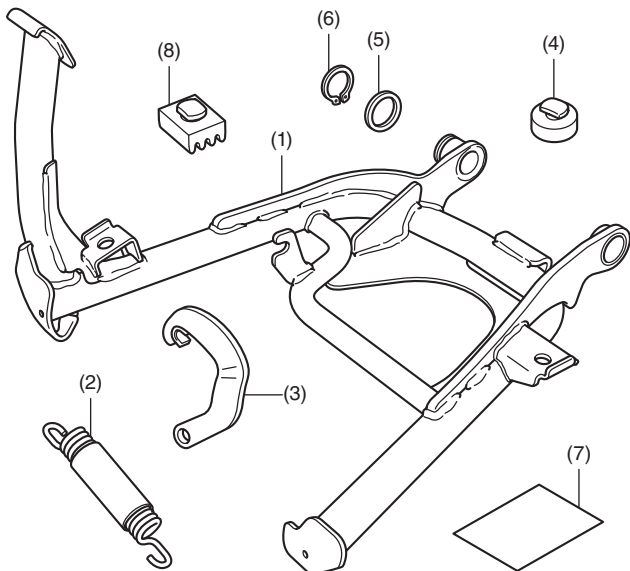

No.	Description	Qty
(1)	Centerstand	1
(2)	Spring	2
(3)	Spring plate	1
(4)	Stand stop, round	1
(5)	Washer	1
(6)	Circlip	1
(7)	Installation Instruction URL	1
(8)	Stand stop, rectangle	1

SUPPLIES REQUIRED

- Snap ring pliers
- Spring tool
- Grease
- Dish soap solution (Water : Dish soap / 100 : 1)
- Shop towel

INSTALLATION

CAUTION

- To prevent burns, allow the engine, exhaust system, radiator, etc., to cool before installing the accessory.

NOTE:

- Be extremely careful when installing the springs as the combined tension of the springs is very strong.
- Keep the motorcycle on its side stand when installing the centerstand.
- The spring installation should be performed by two people. While one person holds the motorcycle, the other person installs the spring.

1. Apply dish soap solution to the position shown.

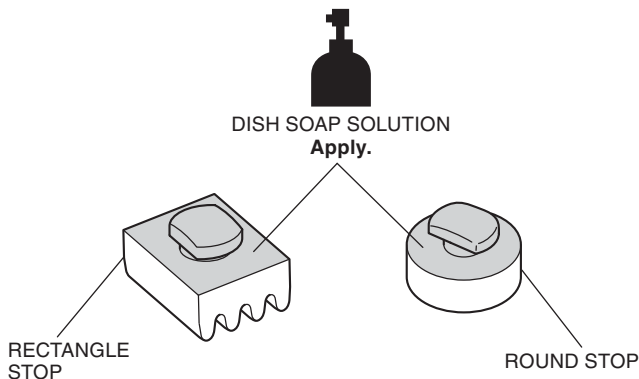

2. Install the rubbers in the position shown.

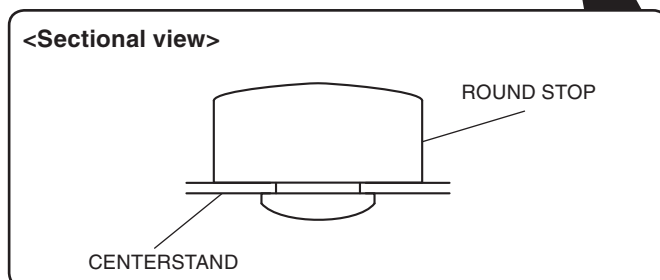
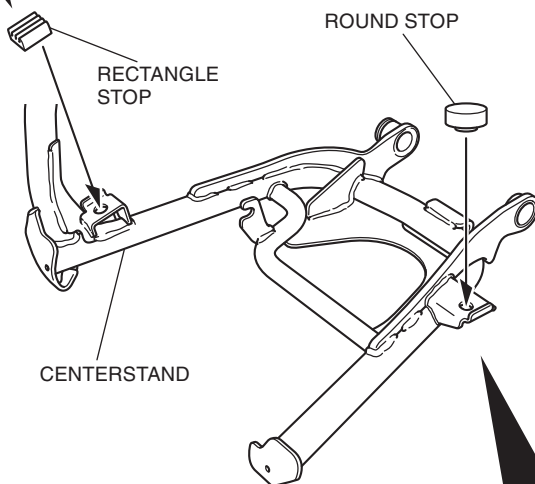
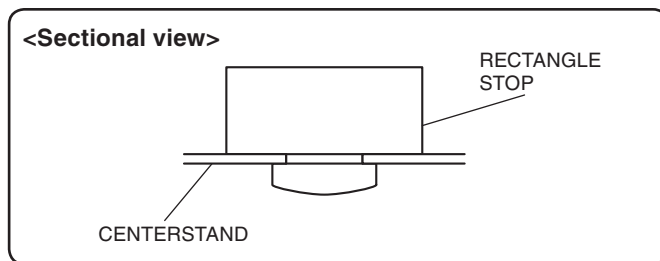

3. Apply grease to the position shown.

<Right side>

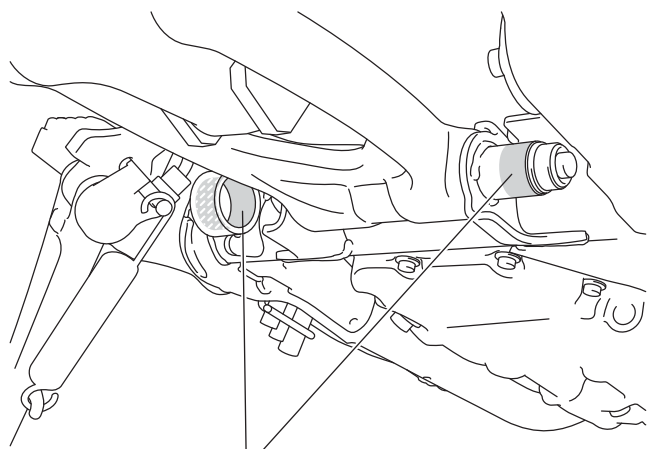

GREASE
Apply to the marked surfaces.

4. Apply grease to the position shown.

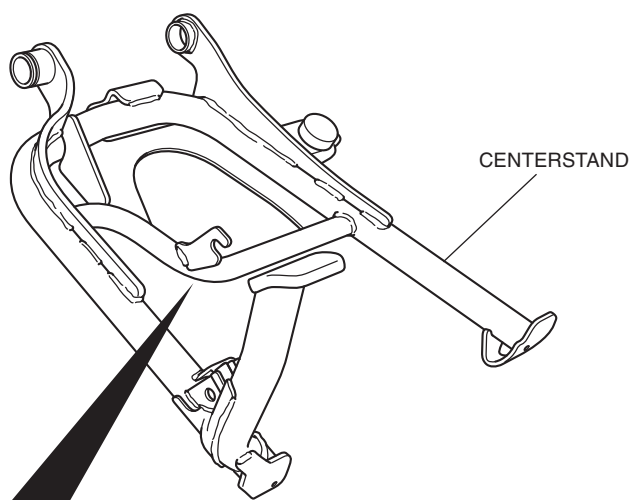

CENTERSTAND

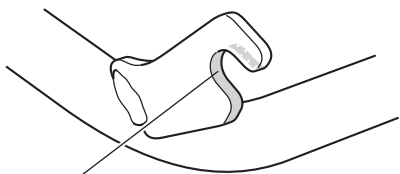

GREASE
Apply to the marked surfaces.

5. Install the centerstand as shown.

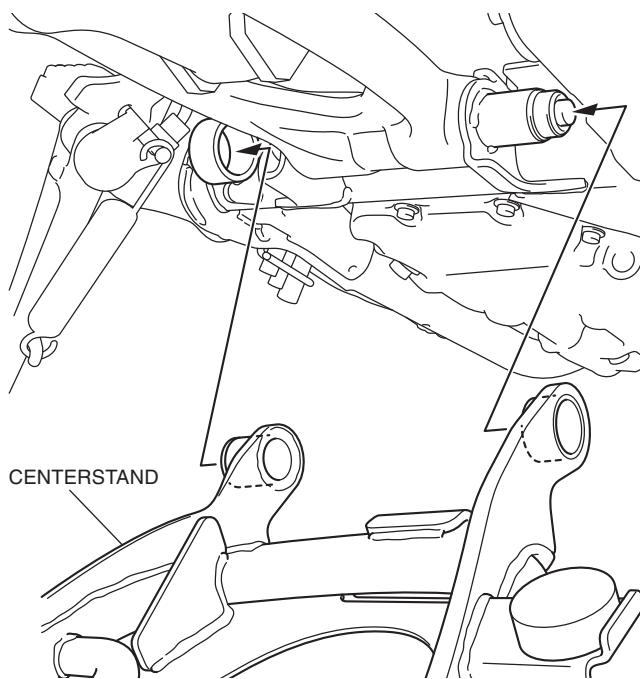

CENTERSTAND

6. Install the circlip and washer as shown.

<Left side>

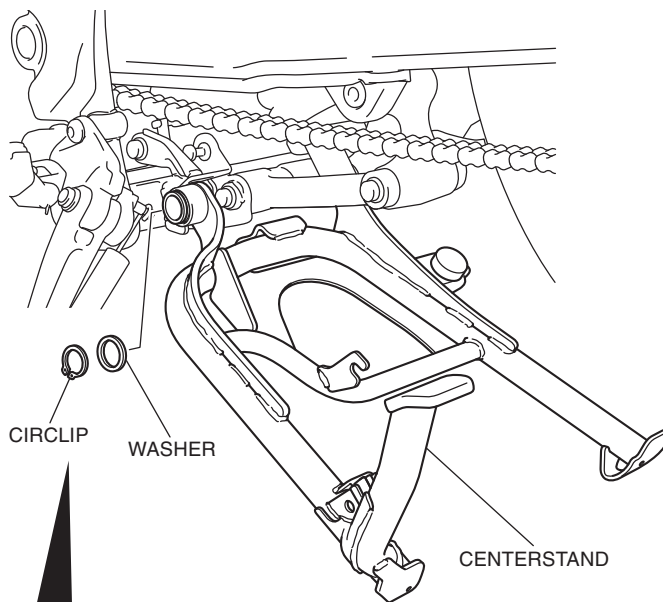

CIRCLIP
WASHER

CENTERSTAND

Install the circlip in the groove in the indicated direction.

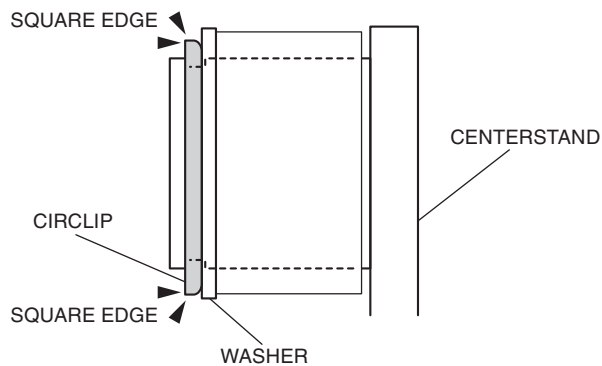

7. Apply grease to the position shown.

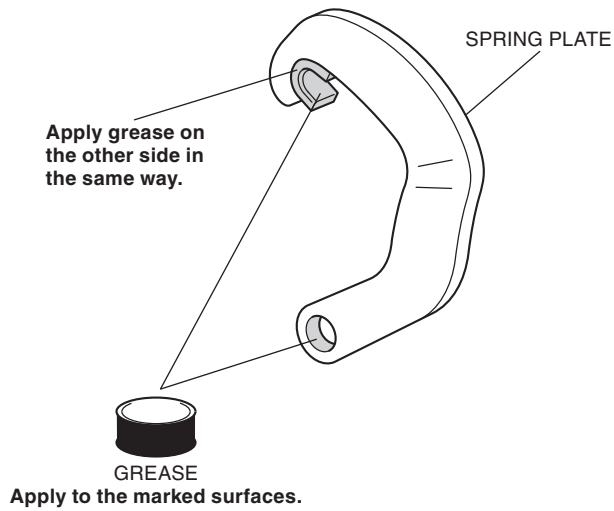

8. Install the springs to the spring plate as shown.

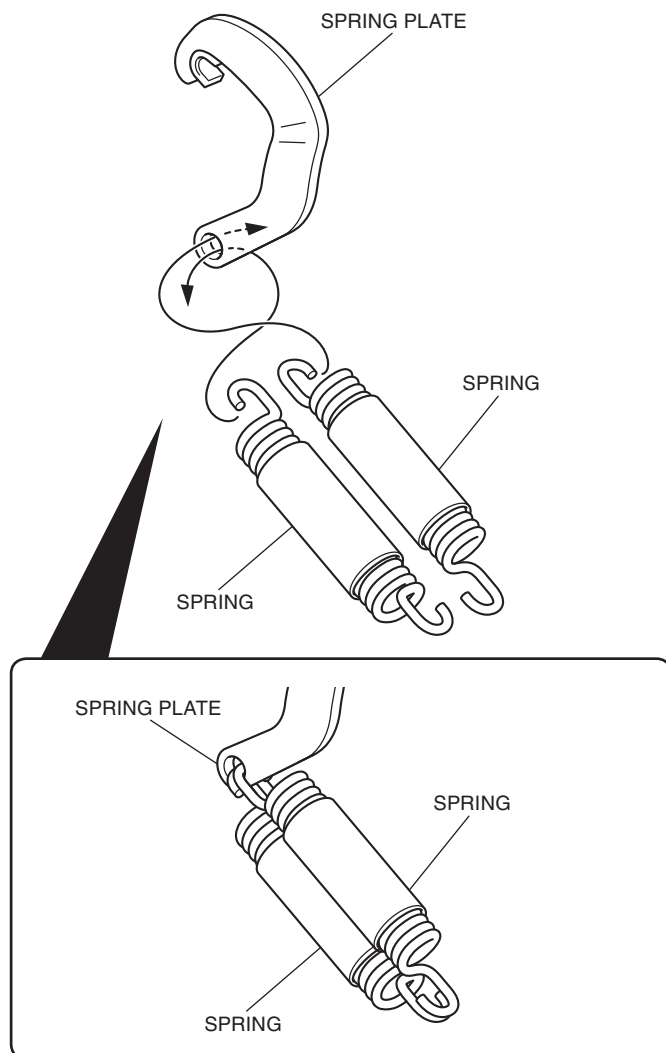

9. Apply grease to the position shown.

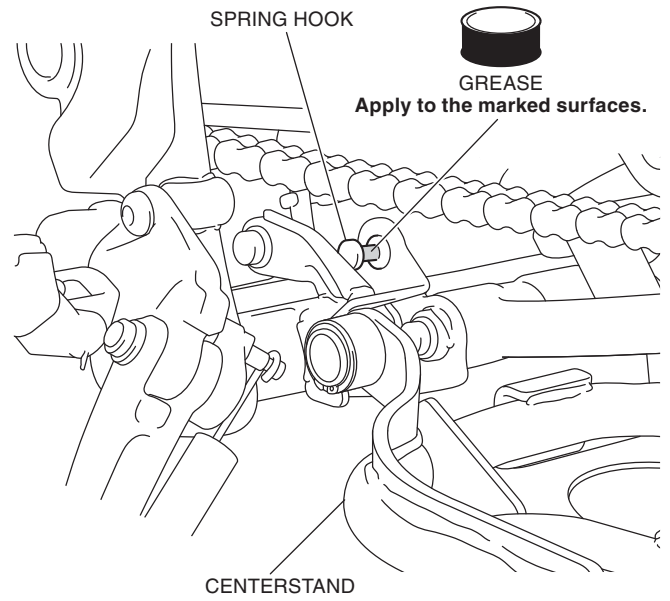

10. Install the spring plate as shown.

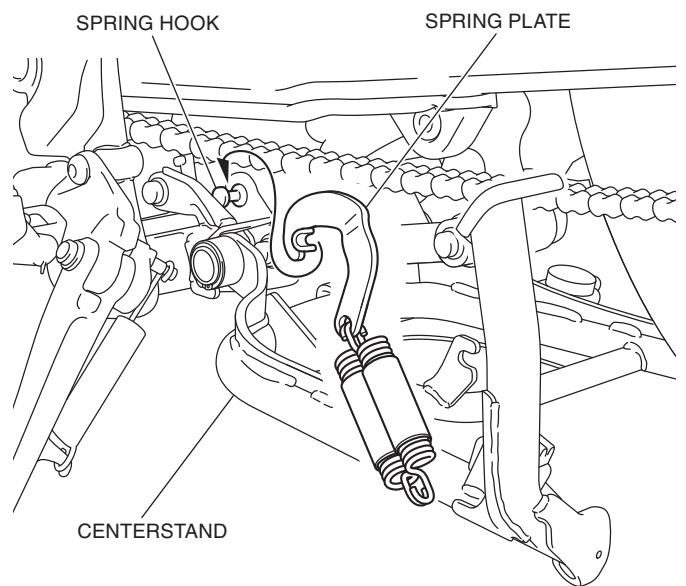

11. Install the springs as shown.

- **The spring installation shall be performed by two people. While one person holds the motorcycle, another person installs the springs.**

